



SJIII 4626 | SJIII 4632 | Test DC ELECTRIC SCISSOR LIFTS

Skyjack's DC Electric Scissor Lifts offer high capacity and large platform areas, making them suitable for any on-slab application. Featuring variable speed rear wheel hydraulic drive, Skyjack 4626 and 4632 scissor models offer working heights up to 11.75 m and 25% gradeability.

A standard 1.22 m roll out extension deck can be secured in multiple positions, and both models can be driven at full height. Consistent with Skyjack's robust and reliable design features, Skyjack DC Electric Scissor Lifts utilize our standard color coded and numbered wiring system with analog based controls.



SKYJACK

DC ELECTRIC SCISSOR LIFTS

SPECIFICATIONS

SJIII 4626

SJIII 4632

2006/42/CE

A Work Height	9.92 m	11.75 m
B Raised Platform Height	7.92 m	9.75 m
C Lowered Platform Height	1.14 m	1.23 m
D Overall Width	1.17 m	1.17 m
E Overall Length	2.31 m	2.31 m
F Stowed Height (Rails Up)	2.15 m	2.24 m
G Stowed Height (Rails Down)	1.79 m	1.88 m
H Platform Width (Inside Dimension)	1.07 m	1.07 m
I Platform Length (Inside Dimension)	2.13 m	2.13 m
Extension Deck (Roll Out)	1.22 m	1.22 m
Ground Clearance (Stowed)	8.89 cm	8.89 cm
Ground Clearance (raised)	1.91 cm	1.91 cm
Wheelbase	1.75 m	1.75 m
Weight	2170 kg	2300 kg
Gradeability	30%	25%
Turning Radius (Inside)	1.21 m	1.21 m
Turning Radius (Outside)	2.37 m	2.37 m
Lift Time (With Rated Load)	54 sec	59 sec
Drive Speed (Stowed)	3.2 km/h	3.2 km/h
Drive Speed (Raised)	1.1 km/h	1.1 km/h
Maximum Drive Height	Full Height	Full Height
Capacity (Overall)	454 kg	317 kg
Maximum # of Persons	3	2

STANDARD FEATURES

- Drivable at full height
- Variable speed, rear two wheel hydraulic drive
- Dual holding brakes
- Proportional controls for drive & lift functions
- 1.22 m roll out extension deck
- 24V DC power source
- Low voltage battery protection
- Analog control system
- Colour coded and numbered wiring system
- Up to 30% gradeability
- Solid rubber, non-marking tyres
- Pothole protection system
- Wiring for AC outlet on platform
- Tilt alarm with drive & lift cut-out
- Overload sensing system
- Lowering warning system
- Operator horn
- Hinged railing system
- Half height spring hinged gate
- Lanyard attachment points
- Forklift pockets and tie down/lift lugs

OPTIONS‡

- Flashing light
- Airline to platform
- 250 Ah batteries
- Hinged railing system
- Full height spring hinged gate
- All motion audible alarm
- Pipe racks
- Drywall/board carrier

‡Capacities, and machine weights may differ when options are added

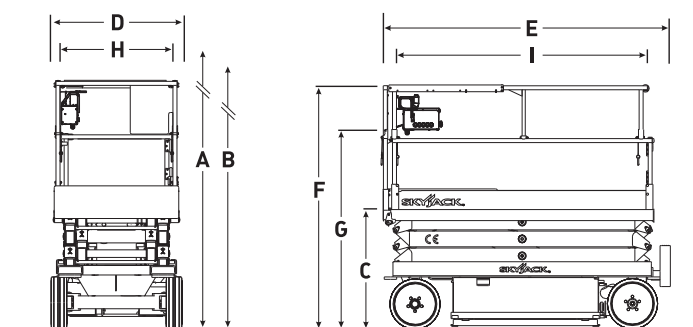

Skyjack Head Office

55 Campbell Rd. Guelph, ON Canada
N1H 1B9
Sales Inquiries: 1-877-755-4387
(1-877-SJLIFTS)
Main Switchboard: 1-800-265-2738
Phone: 1-519-837-0888
Fax: 1-519-837-8104
Email: skyjack@skyjack.com

www.skyjack.com

Skyjack UK

Unit 1, Maes-y-Clawdd
Maesbury Road Industrial Estate
Oswestry, Shropshire, SY10 8NN
Tel: +44 1691 676235
Fax: +44 1691 676239
Email: info@skyjackeurope.co.uk

Skyjack France

ZI Le Clairin
69700 Saint Romain en Gier
France
Tel: +33 (0) 4 78 73 53 32
Fax: +33 (0) 4 78 56 52 42

Skyjack Hebebühnen GmbH (Deutschland)

Därmanbusch 2a
58456 Witten
Tel: +49 (0)2302 20 26 909
Fax: +49 (0)2302 20 25 671

Skyjack AB (Sweden)

Marieholmsgatan 2
415 02 Göteborg
Sweden
Tel: +46 31212245
Fax: +46 31212066



SKYJACK™

This brochure is for illustrative purpose only and based on the latest information at the time of printing. Skyjack Inc. reserves the right to make changes at any time, without notice, to specifications, standard and optional equipment. Consult the Operating Maintenance and Parts Manuals for proper procedures. CE marked work platforms are in conformance to Machinery Directive 2006/42/EC.