

Art. 515.3545

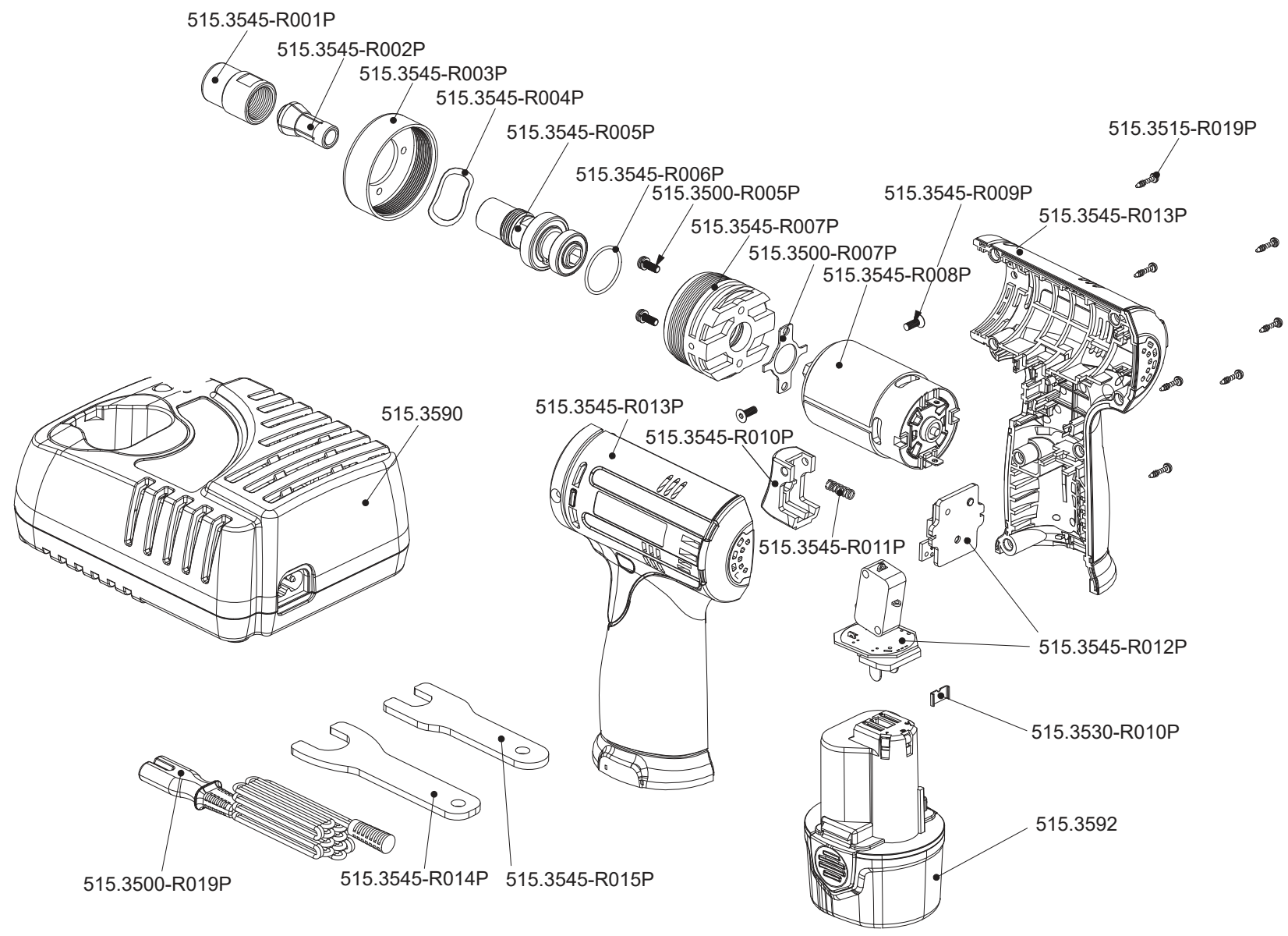

Art. 515.3545

Art.-Nr.	Description	Beschreibung	Menge Qty.
515.3500-R005P	Screw for motor mounting	Schraube für Motorhalterung	2
515.3500-R007P	Gasket	Dichtung	1
515.3500-R019P	Power cord	Stromkabel	1
515.3515-R019P	Side panel screw	Schraube für Seitendeckel	7
515.3530-R010P	Housing fixture	Gehäuseklammer	1
515.3545-R001P	Collet nut	Klemmhülsenmutter	1
515.3545-R002P	Collet	Klemmhülse	1
515.3545-R003P	Front cover	Gehäusefront	1
515.3545-R004P	Shaft seal	Wellendichtring	1
515.3545-R005P	Collet mounting	Klemmhülsenaufnahme	1

Art.-Nr.	Description	Beschreibung	Menge Qty.
515.3545-R006P	O-Ring	O-Ring	1
515.3545-R007P	Motor bracket	Motorhalterung	1
515.3545-R008P	Electric motor	Elektromotor	1
515.3545-R009P	Screw for housing ring	Schraube für Gehäuse ring	2
515.3545-R010P	Trigger	Abzug	1
515.3545-R011P	Trigger spring	Abzugfeder	1
515.3545-R012P	Main switch with PCB	Hauptschalter und Platine	1
515.3545-R013P	Housing left + right	Gehäuse Links + Rechts	1
515.3545-R014P	Wrench 17mm	Schlüssel 17mm	1
515.3545-R015P	Wrench 12mm	Schlüssel 12mm	1